

# CHATTERTOOL

*Robert Sorby*

The Robert Sorby Chattertool is an essential accessory for any woodturner wanting unique decorations on endgrain. The two double ended cutters allow for a myriad of patterns to be achieved by changing the length, cutter shape and lathe speed. You can also use them stationary or traversing across the face of the work piece. The tool can also be converted into a shear scraper with the multi-faceted shear cutter.

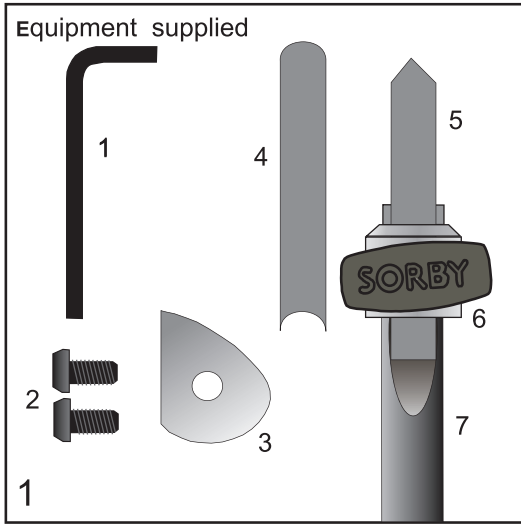

1. Allen key/wrench      6. Chatter cutter holder  
 2. Screws for Scraper cutter      7. Chattertool  
 3. Scraper cutter (Only included in RS215KT not RS216)  
 4. Dome/Hollow Chatter cutter  
 5. Square/pointed Chatter cutter

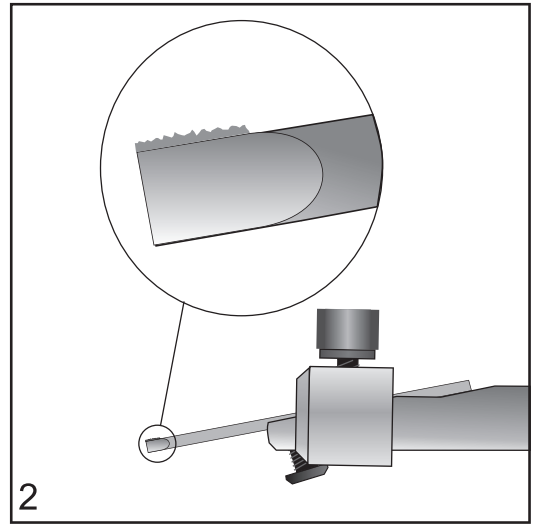

2. The Chatter cutters use a fine burr on the upper face to assist in the flexing action of the cutter, pulling it downwards to create the chatter effect.

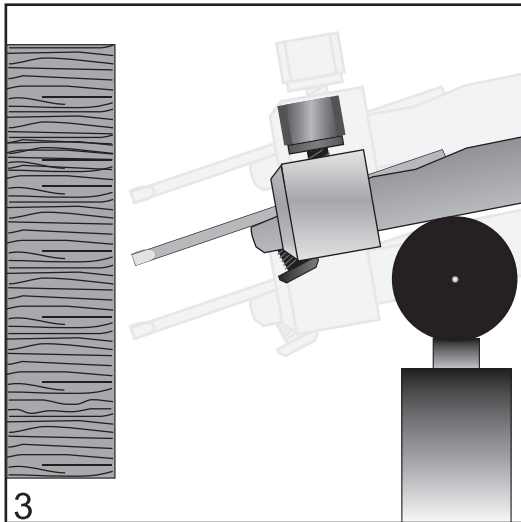

3. One of the many ways to change the pattern created is by altering the height of the tool rest to offset the cutter height, either on above or below centre. The amount of flex and size of pattern is determined by the length of protrusion of the cutter.

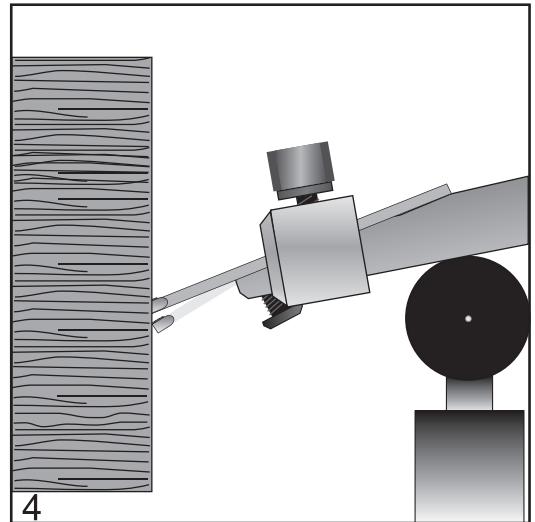

4. Place the tool rest at the required height and approach the wood with the cutter pointing down. When the cutter touches the wood the cutter will flex downward and then spring back creating the chatter effect.

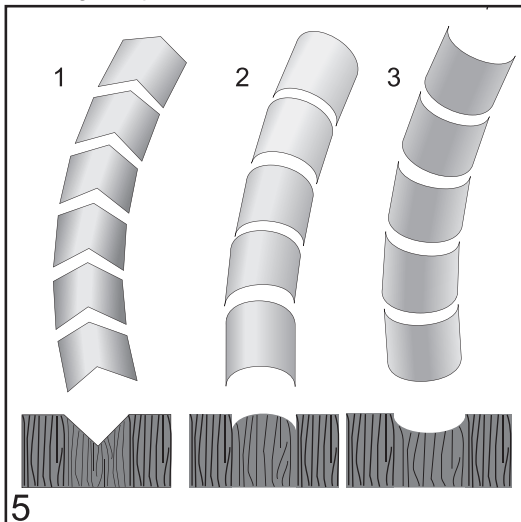

5. Samples of the various patterns that can be created by the different cutters.  
 1. Pointed cutter  
 2. Hollow cutter  
 3. Dome cutter

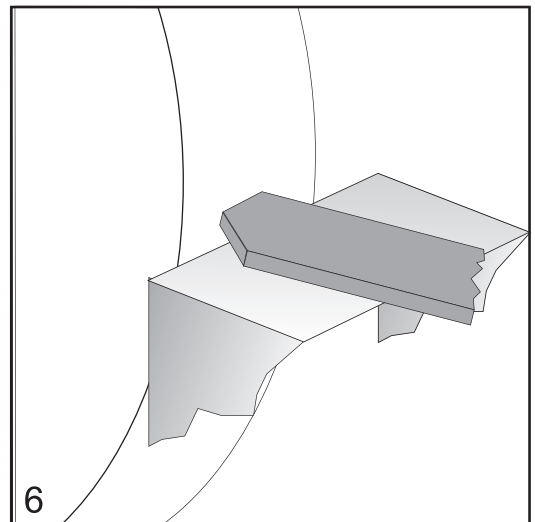

6. Offer the cutter upto a coarse grinding wheel to create the required burr. This must be turned over when returned into the cutter holder as the burr needs to be uppermost.

The Robert Sorby Chattertool can be easily converted to an excellent mini-shear scraper by removing the chatter cutter holder and placing the scraper cutter onto the sloping face. The scraper cutter has a straight edge for use on flat work and the outside of bowls. It also has a multi-curved edge which can be rotated to suit the inside of bowls for shear scraping.

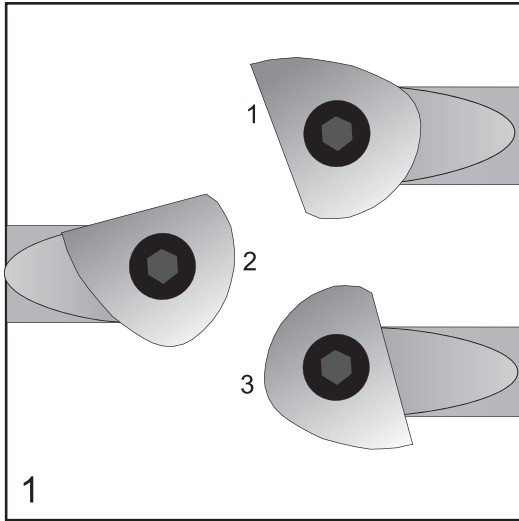

Various ways that the scraper cutter can be used.  
 1. Straight edge  
 2. Shallow curve  
 3. Tight radius

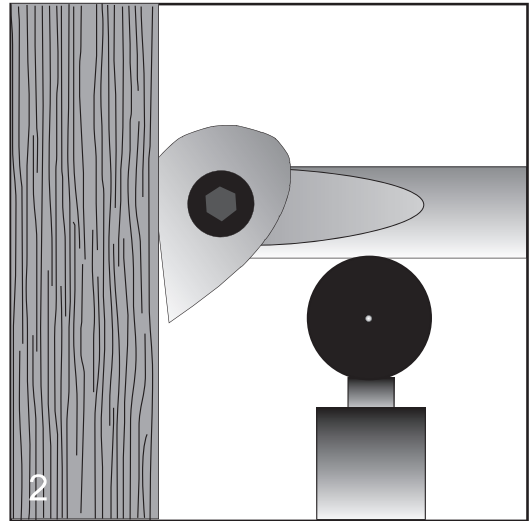

The tool rest should be placed around centre height and as close to the work as safely possible. The tool should be held at a 45 degree angle facing the direction of travel. Working from the right the cutter should be on 8 and 2 on a clock face.

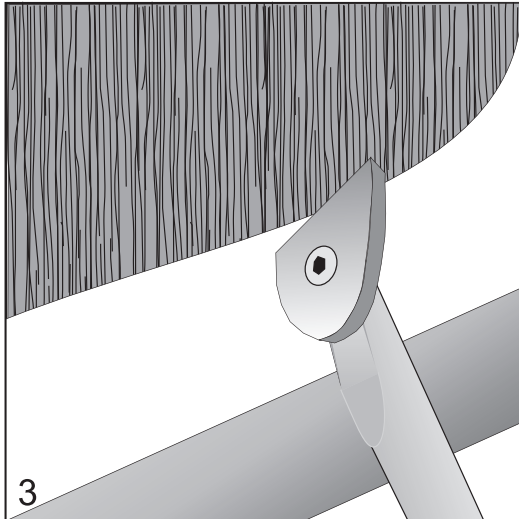

Using the straight edge of the cutter the outside of the work can be shear scraped give a near perfect finish. This reduces the amount of sanding that will be required and minimises dust created in the workshop.

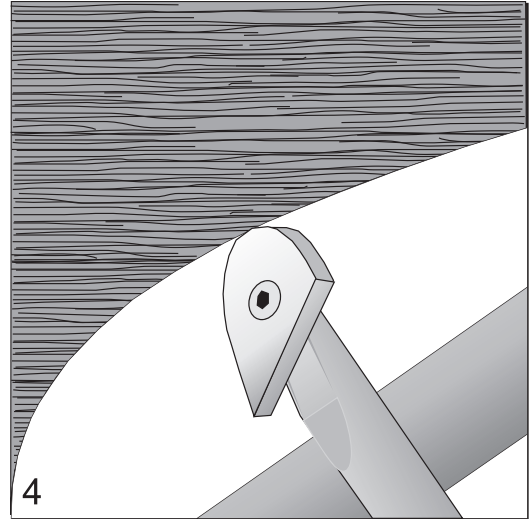

The multi-curved edge can be used to suit the required curve of the work being shear scraped, by loosening the screw with the Allen key/wrench and turning the cutter to the desired curve.

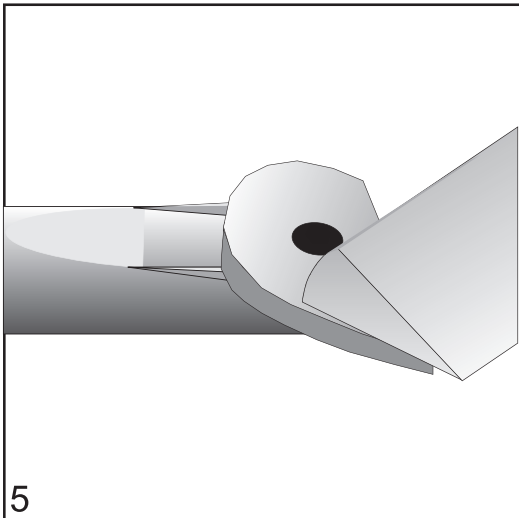

The cutter is best sharpened using a fine honing stone or diamond file across the large flat face.

*Robert Sorby*

Athol Road  
 Sheffield

England S8 0PA

Tel: +44 (0) 1142250700

Fax: +44 (0) 1142250710

sales@robert-sorby.co.uk

www.robert-sorby.co.uk